

Brand guidelines



Table of contents

Introduction	3	Brand identity	11	Contact	39
Overview	4	Logo: overview	12		
		Logo: clear space and minimum size	13		
Brand strategy	5	Logo: usage (color)	14		
Brand platform	6	Logo: background usage	15		
Brand Manifesto, Mission and Vision	7	Logo: favicon and social icons	17		
Voice and tone: rationale & qualities	8	Logo: incorrect use	18		
Writing guidelines	9	Brand architecture	19		
Footer usage guidelines	10	Product logos: color and usage	20		
		Brand elements	21		
		Color palette: overview	22		
		Color palette: specifications	23		
		Color palette: typography	24		
		Color palette: data vis	25		
		Color palette: usage	26		
		Color palette: incorrect use	28		
		Typography: overview	29		
		Typography: display font	30		
		Typography: text and accent fonts	31		
		Typography: usage	32		
		Graphic language: iconography style	33		
		Graphic language: pictograph style	34		
		Graphic language: pictograph usage	35		
		Graphic language: illustration style	36		
		Graphic language: design scale	37		
		Graphic language: product display	38		

This is an interactive PDF. Use this table of contents and the top nav panel to easily navigate through this document.



Introduction

This document is a guide for anyone writing, designing, or producing Auvik branded communications. It will help us capitalize on the brand's strengths and will serve as a guide to protect the integrity of the brand from incorrect usage.

Inside, you will find an overview of our core design elements and basic rules around how these elements can be applied to various communications. These are the key building blocks of our brand expression. Understanding our brand and using these tools correctly and consistently is crucial.

Introduction

system overview

With its playful and optimistic graphic language and typography, along with its simple yet sophisticated color palette, Auvik's brand identity is uplifting and friction-free.

The primary elements of Auvik's visual identity are shown here: logo, color palette, typography, illustrations, and iconography.

Together, these elements form a flexible system for creating stories and experiences that amplify the Auvik brand.

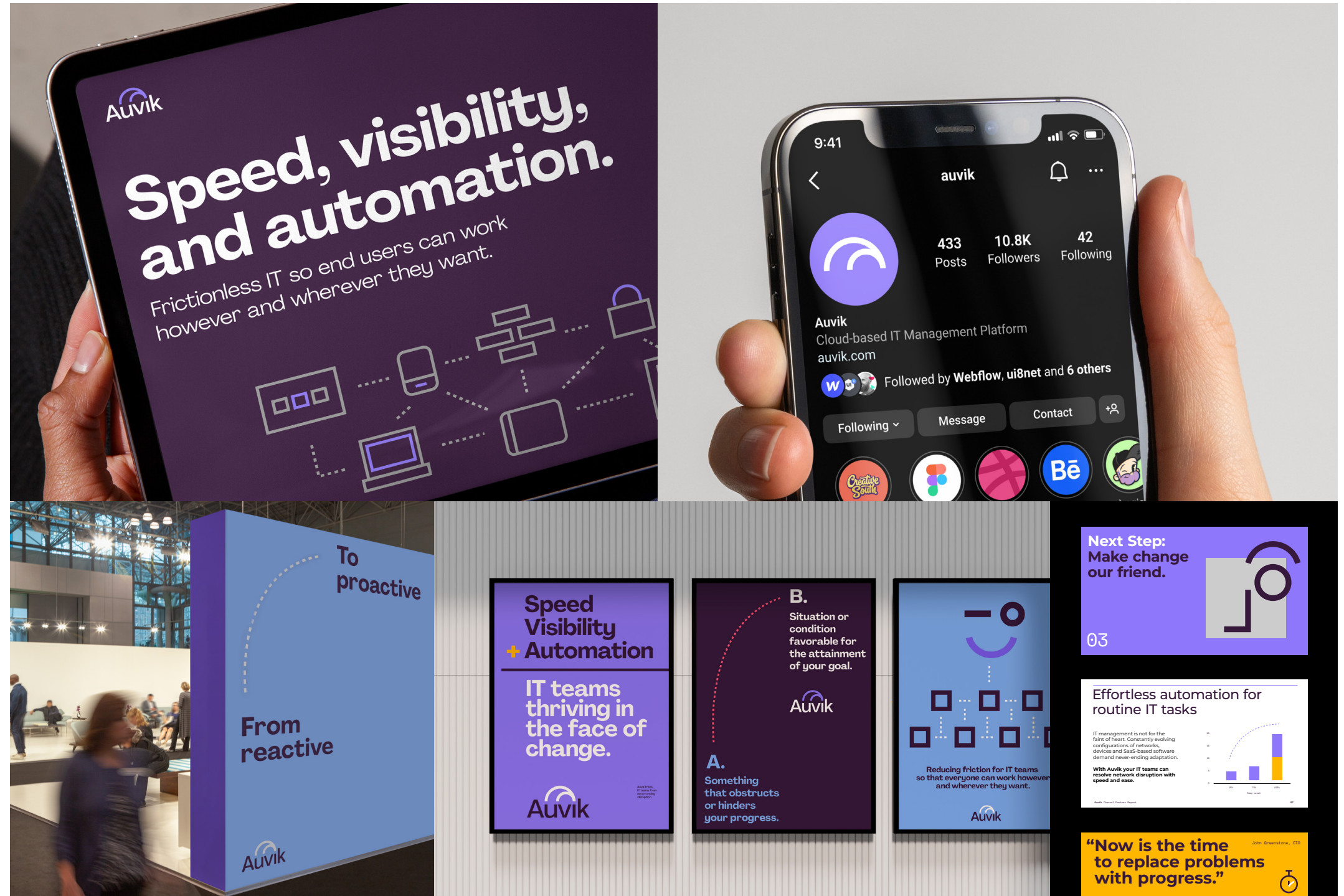



Brand strategy

Brand strategy informs and directs every aspect of brand expression. Alignment around brand strategy is key to achieving the greatest impact. What we do, what we say, and how we present ourselves impacts brand perception.

Brand strategy

The Brand strategy is the foundation of your Brand, and it comprises Brand Pillars, Positioning Statement, Emotional Impact, and Brand Idea.

The Brand Idea is the essence or embodiment of what we stand for. It gives an emotional dimension to the brand. It is used to guide look, feel, and voice.

Brand Positioning is the singular, differentiated and relevant idea you want to stand for in the minds of your customers.

Emotional Impact is defined by how the Auvik brand makes people feel. It is a set of three positive emotions that drives the behavior of the brand across all experiences and touchpoints.

Brand Pillars are the evergreen, authentic truths about Auvik. All our communications should accurately reflect one or more of our Positioning Pillars to ensure a cohesive story across all experiences and touchpoints.

Our audience is unified by an overarching psychographic profile, and all brand expressions should resonate with this target.

Brand Idea

Change without friction

Positioning

Auvik empowers IT teams to confidently navigate change with less friction.

Emotional Impact

Powerful

Unburdened

Excited

Positioning Pillars

What

Embrace change

IT professionals are confronted with change at every turn due to rapidly evolving IT environments. Auvik's cloud-based IT Management platform provides them with the visibility and agility they need to confidently navigate change and accelerate progress.

How

Absolute simplicity

Auvik's cloud-based suite of tools deploys quickly and seamlessly to give IT teams the ability to proactively manage an ever-changing landscape of networks, endpoints and SaaS applications.

Why

Remove friction

A culture of resilience coupled with software that delivers total visibility and effortless automation allows IT teams to give end users the freedom to work wherever and however they like. IT professionals and their end users not only weather change, but emerge even stronger.

Audience

MSPs and IITs whose greatest challenge AND opportunity is to provide the optimal level of agility to their users while maintaining visibility, security and control.

Brand Manifesto, Mission & Vision

The Brand Manifesto pulls all of the key elements of the brand strategy into a meaningful short-form narrative. Unlike the elements of the strategy which is heavy on strategic language that means more to us internally, the manifesto is more plain-spoken and externally-facing. It can and should be used to inform all manner of other written communications. It is the bedrock of our message to the world about who we are and why we matter.

Auvik's Mission is a concise statement that defines its core purpose and reason for existence. It articulates what Auvik does, who it serves, the value it provides, and how it will achieve this mission.

Auvik's Vision is a forward-looking statement that describes its long-term aspirations and goals. It conveys Auvik's ideal future and the impact it aims to achieve in the world.

Together, Auvik's Mission and Vision serve as guiding principles that shape the company's strategy, culture, and decision-making, helping it stay focused on its objectives and values.

Brand Manifesto

Change without friction

IT management is not for the faint of heart. Constantly changing IT environments demand never-ending adaptation. IT teams need visibility, security and control over their entire infrastructure, even in the face of constant change.

Auvik's IT management platform enables IT teams confidently navigate change with less friction. The key is absolute simplicity: seamless deployment, an intuitive interface, and effortless automation. The result is ultimate visibility, security and control of an ever-changing landscape of networks, endpoints and SaaS applications. Auvik ensures that change is frictionless for IT teams, so that everyone can work however and wherever they want.

Mission

To reduce friction for IT teams so that everyone can work however and wherever they want.

Vision

A world where frictionless information technology accelerates everyone's potential.

Voice and tone rationale & qualities

Maintaining a consistent voice and tone in brand messaging is paramount as it fosters brand recognition and trust among customers, ensuring that the brand's identity and values resonate clearly and cohesively across all communication channels.

To reflect Auvik's embrace of change, our voice must serve as a spark—a clear signal of our forward-leaning, action-oriented stance. It's also critical that our communications demonstrate expertise and leadership, to lend credibility to our positioning. By encouraging IT professionals to think about change differently, rallying them to push beyond limits, and giving them the tools they need to do so, we help them feel powerful, unburdened and excited, as they imagine a world where change can be frictionless.

Tone quality 1

Passionate

We are obsessed with creating a world where change can be frictionless, and are incredibly excited for how this can positively impact our customers.

We choose to lead because we are vested in our customers and what we can help them achieve, together.

Tone quality 2

Approachably brilliant

We are an ally for our customers and prospects - we know them and we know the IT world. Through forming real connections and leveraging our ever evolving experience, we can help them see the path to success with Auvik.

Tone quality 3

Self-aware

We know we're brilliant and offer amazing products, but we also know there's always more to learn, and recognize the importance of having a growth mindset.

Listening is more important than knowing, and it strongly influences our path forward.

Writing guidelines

Auvik's writing guidelines are a set of rules and principles that dictate how written content should be crafted, ensuring consistency and a cohesive brand voice across all communication channels. They are essential for maintaining brand integrity, enhancing recognition, and establishing a strong and trustworthy brand identity in the eyes of customers.

Guideline 1

Get to the point, respectfully

- Our platform offers simplicity and ease. Our communications should do the same. As a company that removes barriers to progress, it's critical that our voice is helpful—never getting in the way.
- Avoid complex sentence structure, but don't speak down to our audiences. They appreciate the simplicity we bring to the equation yet they are our equals in every way.

Guideline 3

Infuse our (awesome) personality

- Speak to our audience as a genuine human - minimize corporate buzzwords and jargon, remain respectful and professional, but with a sense of humor.
- We encourage bold, attention-grabbing headlines that ignite curiosity, make us memorable, and maybe get a chuckle here and there.

Guideline 2

Kindle aspiration

- Invite people to connect with us on how to think bigger and bolder. Show them we see them and know how our capabilities can impact their specific business challenges.
- Challenge audiences to rethink what's possible and that we are right there with them on this journey. outside of their typical belief systems.

Guideline 4

Make IT the hero

- Every IT pro has two primary goals: keep end users productive and solve high pressure problems using their technical expertise. Auvik empowers them to succeed at both, and we need to reinforce this.
- We celebrate IT's pivotal role in helping end users succeed. This is a unique viewpoint and should be leveraged not only to help us stand out amongst our competitors, but to truly have our audiences connect with us and feel empowered in their roles.

Footer usage guidelines

Footers provide consistent brand identification and navigation across Auvik marketing assets. Footer treatments vary by asset length to balance clarity, usability, and visual simplicity.

One-pagers, overviews, sell sheets, brief PDFs

Short-form assets

- Footer appears on the page(s) where appropriate, typically aligned to the bottom margin.

eg. www.auvik.com | 888-609-2011

- The copyright notice must appear on the **final page only**.

- Use the following copyright statement verbatim on the final page:

© Copyright 2013-2026 Auvik Networks Inc. All rights reserved. Auvik, the logo, and other identifiers of Auvik goods or services are trademarks of Auvik Networks Inc and may not be used without express written permission. All other trademarks, service marks, trade dress, and logos are the property of their respective owners. Reference to them does not imply sponsorship, affiliation, or endorsement.

eg. Front page



eg. Final page



E-books, reports, white papers

Long-form assets

- Footer appears on every page.

eg. www.auvik.com | Title of the asset | Page number

- Page numbers should be sequential and clearly legible.

- Include the following copyright statement on the **final page only**, unless legal or regulatory requirements specify otherwise:

© Copyright 2013-2026 Auvik Networks Inc. All rights reserved. Auvik, the logo, and other identifiers of Auvik goods or services are trademarks of Auvik Networks Inc and may not be used without express written permission. All other trademarks, service marks, trade dress, and logos are the property of their respective owners. Reference to them does not imply sponsorship, affiliation, or endorsement.

eg. Every page



eg. Final page

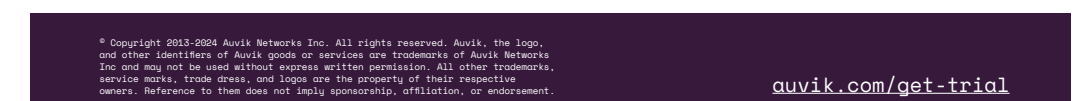



Brand identity

The Auvik brand identity is the visual manifestation of the Brand Idea—Change without friction. As such, it is vital to implement all aspects of the brand identity in a consistent and thoughtful manner.

Logo: overview

The Auvik logo not only embodies the brand idea and visually connects us to the story of *Change without friction* but also maintains a connection with the history of the brand and its previous logo. The symbol—a double rising arc—sits atop a newly crafted wordmark and acts as a visual cue to the forward momentum that change brings. The clean, rising arcs act as a connective thread throughout the Auvik brand language—infographics, iconography, data visualization, motion graphics—to further tell the story of how Auvik helps IT professions rise to the challenges that change can bring and propel them towards progress with less friction.



Logo: clear space and minimum size

The Auvik brand identity must appear clearly and legibly in all applications.

Clear space

Clear space is the area surrounding our logo that must be kept free of any visual elements—text, graphics, borders, patterns, other logos, etc. Shown here are specifications for the minimum clear space you should use for our logo.

Minimum size

The minimum size is the smallest our logo can appear without compromising legibility. Shown here are the recommended minimum sizes you should use for both digital and print applications.

If you have an application that requires an even smaller size, please discuss your needs with our brand team.

Note: The minimum size exhibit on this page is shown at 200% scale for clearer illustration.

Clear Space



Minimum Size



Digital: 36 px
Print: 0.375 in / 10 mm

Logo: color variations

Full-color positive and reverse variations

These color variations are the primary expression of our brand. You should use them in most cases.

One-color reverse variation

This variation is for secondary use on any of our brand colors.

Black variation

You can use this special-use variation for b&w print applications, such as newspaper ads, or co-branding situations where our logo has to appear on a color outside of our palette. You can use the one-color reverse variation in these situations as well. Avoid using this variation onscreen or in full-color print applications.



Full-color positive



Full-color reverse (dark)



Full-color reverse (light)



One-color reverse



Black (special-use, print only)

Logo: usage (color)

The approved logo/background color pairings shown to the right have been chosen to be legible and on-brand. These are the only pairings you should use.

For information on our color palette, please see the Brand elements section below.

Note: The Auvik logo may not be placed on imagery.

Full-color positive



Full-color reverse (light)



Full-color reverse (dark)



One-color reverse



White

Dark Purple

Light Purple

Purple

Yellow

Magenta

Cyan

Black

Dark Gray

Gray

Light Gray

Logo: usage (B&W)

To ensure legibility, follow the contrast guide shown to the right when placing the black or one-color reverse logo variation on b&w backgrounds in print applications.

The Auvik logo may not be placed on b&w photographic backgrounds.

Note: The black logo variation may not be used onscreen or in full-color print applications.

White			60% black		
10% black			70% black		
20% black			80% black		
30% black			90% black		
40% black			100% black		
50% black					

Logo: favicon and social icons

You can adapt the Auvik symbol for use as a favicon, as well as an icon in app and social media environments.

When creating new icons, always follow the specifications shown to the right. You can use any of the three approved color combinations specified here. Avoid using any other colors.

The examples shown here are for reference only and have not been built to specification. When creating new icons, always follow developer guidelines.

For examples of our favicon and social icons in use, please see the Brand Applications section.

Construction: social icons

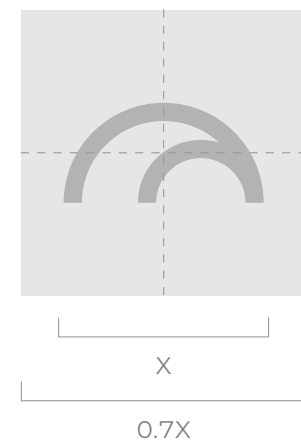

Symbol is centered within square background shape

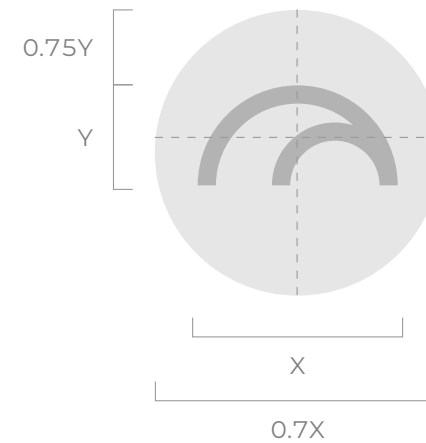

Symbol sits slightly higher within circular background shape to appear visually centered

Construction: favicon

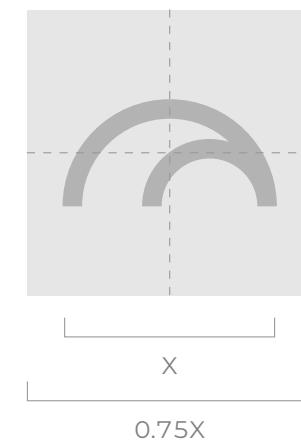

Symbol is centered within square background shape.
Symbol is scaled slightly larger for better legibility at small scale.

Approved color combinations



White on Light Purple (social)



Light Purple on Dark Purple (website)



Light Purple on Black (other & internal enablement)

Logo: incorrect usage

The examples shown to the right illustrate uses you should avoid.

The Auvik logo is custom drawn. Never modify or recreate it or its elements. Always use the logo artwork as provided.



DO NOT disproportionately scale.



DO NOT rearrange elements.



DO NOT change colors.



DO NOT change the font.



DO NOT add special effects.



DO NOT rotate.



DO NOT skew or distort.



DO NOT outline.

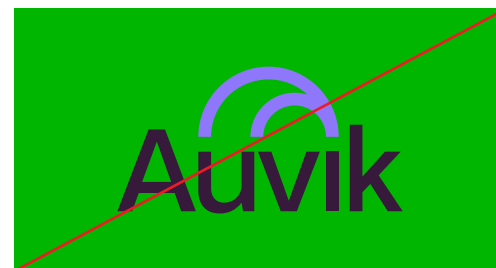

DO NOT place on unauthorized colors.



DO NOT place on photography.



DO NOT separate elements.

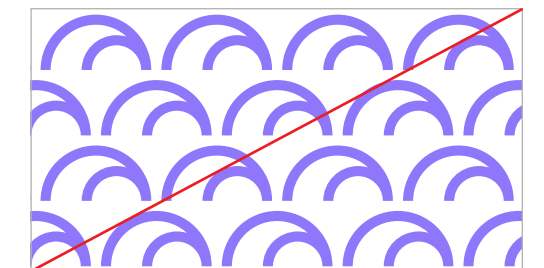

DO NOT create patterns.

Brand architecture

Auvik has three products with their own logos for identification:

- 1) Auvik Network Management (**ANM**)
- 2) Auvik SaaS Management (**ASM**)
- 3) Auvik Endpoint

Each product's branding is tied to the core Auvik identity. To help distinguish Auvik's products from one another for our customers and users there is a simple color coding system:

- 1) Auvik Network Management (**ANM**) = **Light Purple**
- 2) Auvik SaaS Management (**ASM**) = **Cyan**
- 3) Auvik Endpoint = **Yellow**

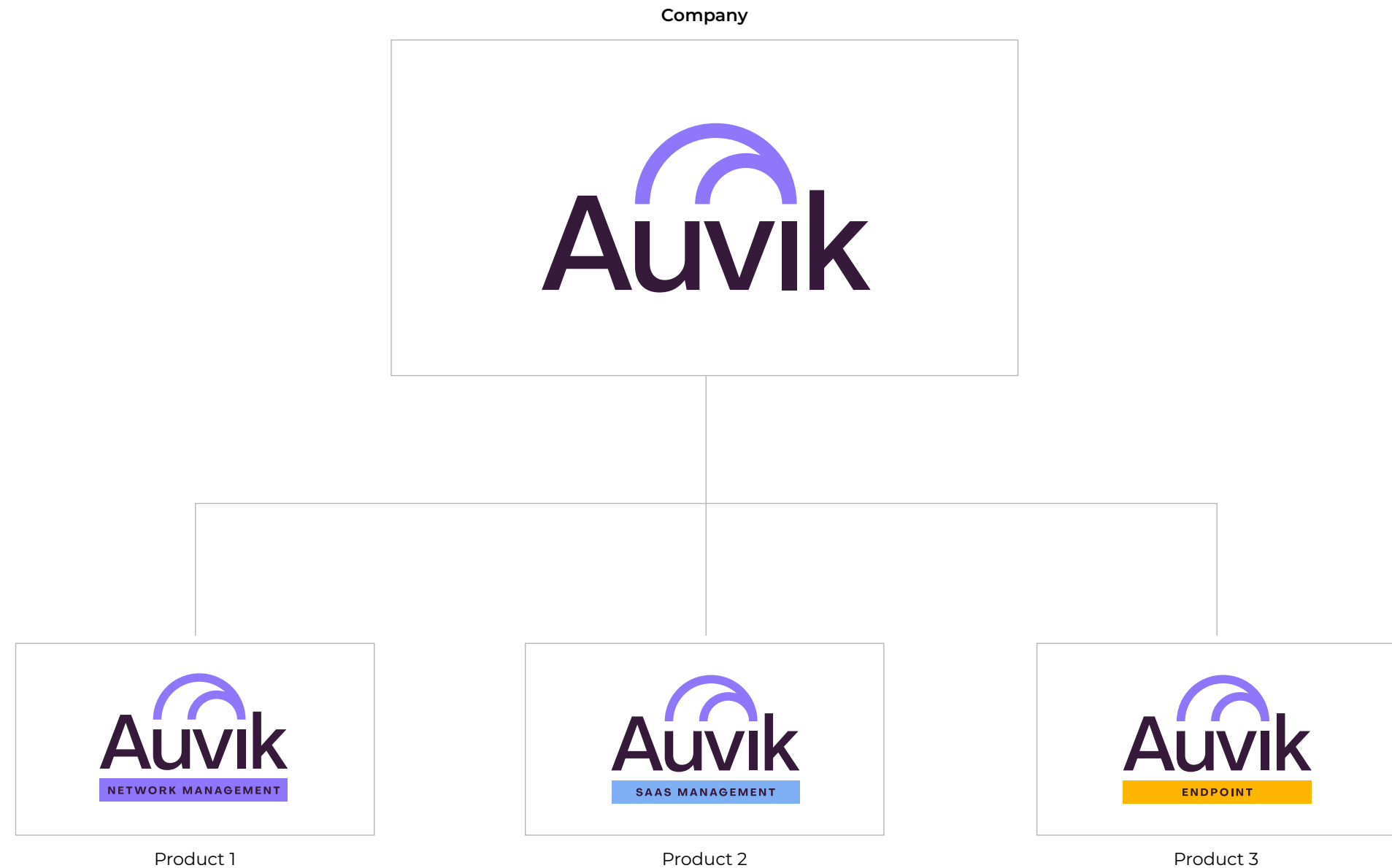

Product logos: color & usage

Product logos and color priority should only be used within the product interface or on product specific material like product overviews or sales sheets.

When using product logos and branding:

- Color and contrast usage must be followed and align with the standards set on pages 13–17.
- The arcs in the logo are never allowed to be anything other than Light Purple or White.
- Other secondary colors may be used in data visualizations and supporting graphics for product assets but should not overtake the product primary palettes shown here.
- All white versions of the product logos may be used when working with a partner on a co-branded piece and the partner's color palette does not allow for the logos seen on this page to maintain proper contrast.

Auvik Network Management (ANM)

ANM product primary palette:



ANM only favicon:



ANM product logo full color for light backgrounds



ANM product logo for dark backgrounds



ANM product logo for bright backgrounds

Auvik SaaS Management (ASM)

ASM product primary palette:



ASM only favicon:



ASM product logo full color for light backgrounds



ASM product logo for dark backgrounds



ASM product logo for bright backgrounds

Auvik Endpoint

Endpoint product primary palette:



Endpoint only favicon:



Endpoint product logo full color for light backgrounds



Endpoint product logo for dark backgrounds



Endpoint product logo for bright backgrounds



Brand elements

This section contains the visual elements that extend the Auvik brand identity. These elements work cohesively to create a recognizable system.

Color palette: overview

At the core of our color palette are Auvik shades of purple. Bright support colors and a variety of neutrals create an energetic, contemporary palette with plenty of flexibility.

Dark Purple

Light Purple

Purple

Yellow

Magenta

Cyan

White

Black

Dark Gray

Gray

Light Gray

Color palette: specifications

Shown to the right are specifications for reproducing our color palette in both digital and print applications.

Auvik colors are based on the Pantone Matching System and current RGB standards. These colors have been carefully chosen to represent our brand and should never be altered.

Note: The Pantone and CMYK colors specified here are for use on coated paper stocks. If an application requires printing on uncoated stock, please work with our brand team and your printer to determine optimum color matches.

The CMYK, RGB, and hex values shown on this page and throughout these guidelines have not been evaluated by Pantone, Inc. for accuracy and may not match the Pantone color standard. Consult current Pantone color publications for accurate color.

Dark Purple

Hex: 37193C

RGB: 55/25/60

CMYK: 83/100/0/44

Pantone: 2627 C

Light Purple

Hex: 8E77FB

RGB: 142/119/251

CMYK: 45/53/0/0

Pantone: 2087 C

White

Hex: FFFFFFFF

RGB: 255/255/255

CMYK: 0/0/0/0

Purple

Hex: 7A5CF2

RGB: 122/92/242

CMYK: 71/80/0/0

Pantone: 2089 C

Yellow

Hex: FFB600

RGB: 255/182/0

CMYK: 0/22/100/0

Pantone: 7549 C

Magenta

Hex: FF5374

RGB: 255/83/116

CMYK: 0/79/31/0

Pantone: 184 C

Cyan

Hex: 7FB0F6

RGB: 127/176/246

CMYK: 49/20/0/0

Pantone: 2142 C

Accessible Cyan

Hex: 5E96E7

RGB: 94/150/231

CMYK: 61/35/0/0

Pantone: 284 C

Black

Hex: 000000

RGB: 0/0/0

CMYK: 0/0/0/100

Pantone: Process Black C

Dark Gray

Hex: 666666

RGB: 102/102/102

CMYK: 63/52/44/33

Pantone: Cool Gray 11 C

Gray

Hex: 999999

RGB: 153/153/153

CMYK: 38/29/24/5

Pantone: Cool Gray 7 C

Light Gray

Hex: CCCCCC

RGB: 204/204/204

CMYK: 24/17/15/0

Pantone: Cool Gray 4 C

Lightest Gray

Hex: F5F5F5

RGB: 245/245/245

CMYK: 3/2/2/0

Pantone: Cool Gray 1 C

Color palette typography

Follow the guidance shown here to create text/background color pairings that are legible and accessible. These pairings pass WCAG 2.0 AAA and AA international standards (where noted) and should be used for both digital and print applications.

Note: Within our color palette, there are additional color combinations that pass accessibility standards. However, they are not part of our visual system, and you should avoid their use.

Dark Purple

- White AAA
- Yellow AAA
- Light Gray AAA
- Light Purple AA
- Magenta AA
- Cyan AA
- Gray AA

Light Purple

- Black AA
- Dark Purple AA
- White AA (large text)

White

- Black AAA
- Dark Purple AAA
- Purple AA
- Dark Gray AA
- Gray (print only)

Purple

- White AA
- Black AA
- Dark Purple AA (large text)

Yellow

- Black AAA
- Dark Purple AAA
- Dark Gray AA (large text)

Magenta

- Black AA
- Dark Purple AA
- White AA (large text)

Cyan

- Black AAA
- Dark Purple AA
- White (print only)

Black

- White AAA
- Yellow AAA
- Cyan AAA
- Gray AAA
- Light Gray AAA
- Magenta AA
- Light Purple AA

Dark Gray

- White AA
- Yellow AA (large text)
- Light Gray AA (large text)

Gray

- Black AAA
- Dark Purple AA

Light Gray

- Black AAA
- Dark Purple AAA
- Dark Gray AA (large type)

Color palette: data visualization

Shown to the right are specifications for reproducing our color palette in both digital and print applications.

These colors are used for data visualization, creating a more robust palette with a designated tertiary level.

Note: The CMYK colors specified here are for use on coated paper stocks. If an application requires printing on uncoated stock, please work with our brand team and your printer to determine optimum color matches.

The CMYK, RGB, and hex values shown on this page and throughout these guidelines have not been evaluated by Pantone, Inc. for accuracy and may not match the Pantone color standard. Consult current Pantone color publications for accurate color.

Data Vis Lilac
Hex: A194FA
RGB: 161/148/250
CMYK: 41/42/0/0

Data Vis Dark Blue
Hex: 2E85ED
RGB: 46/133/237
CMYK: 74/46/0/0

Data Vis Light Yellow
Hex: FFC74D
RGB: 255/199/77
CMYK: 0/23/80/0

Data Vis Lavender
Hex: 8F78FA
RGB: 142/120/250
CMYK: 55/57/0/0

Data Vis Pink
Hex: FC94AD
RGB: 252/148/173
CMYK: 0/53/11/0

Data Vis Tangerine
Hex: FC9445
RGB: 252/148/73
CMYK: 0/51/80/0

Data Vis Grape
Hex: 5C0873
RGB: 92/8/115
CMYK: 76/100/20/13

Data Vis Berry
Hex: B83354
RGB: 184/51/84
CMYK: 22/93/56/7

Data Vis Gold
Hex: D68A03
RGB: 214/138/3
CMYK: 15/50/100/1

EXAMPLE use color usage in data visualization. Choose colors that are clearly differentiated and organized in a way that allows for easy identification.

Use these colors after the primary palette has been exhausted for greater color range and maximum contrast.

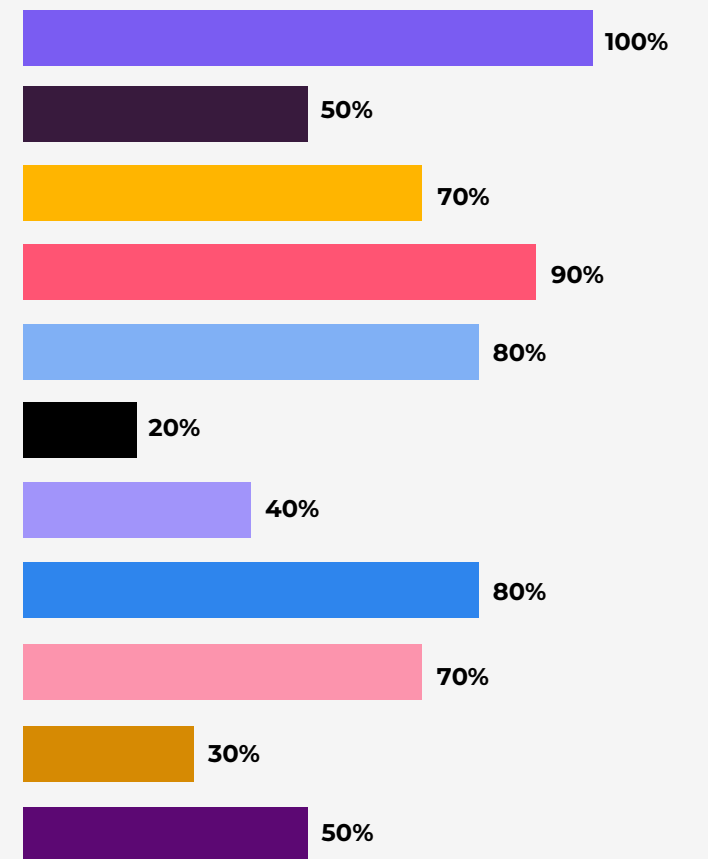

Color palette: usage

Backgrounds

You can use any of our primary ① or secondary ② colors for large background floods. You can also use black sparingly to add to the overall richness of a design, but it should never dominate and should always play a secondary role to Dark Purple. You can use our grays for small backgrounds, but avoid using them for large areas.

Typography

In most cases you should use our primary colors ③ for typography. You can also use our secondary colors ④ for short text passages and small titles, but never on white backgrounds. Avoid using more than two colors (including white) in a single text passage. Use black ⑤ or white for longer text passages and all long-form body copy. Please see the following page for additional guidance on color use in typography.

Graphic elements and infographics

You can use any of our colors, including Neutrals, for graphic elements and infographics ⑥ provided there is sufficient contrast for legibility.

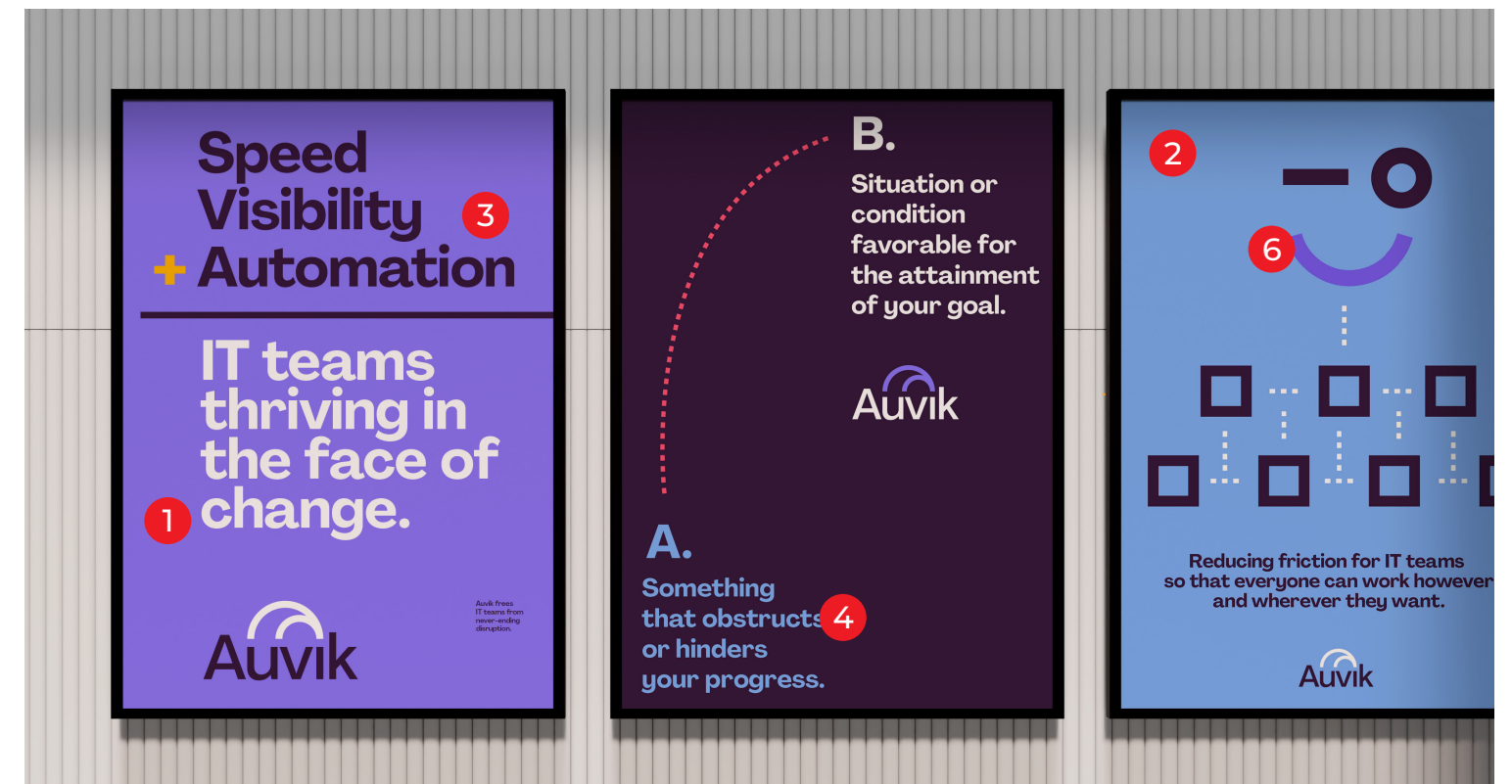
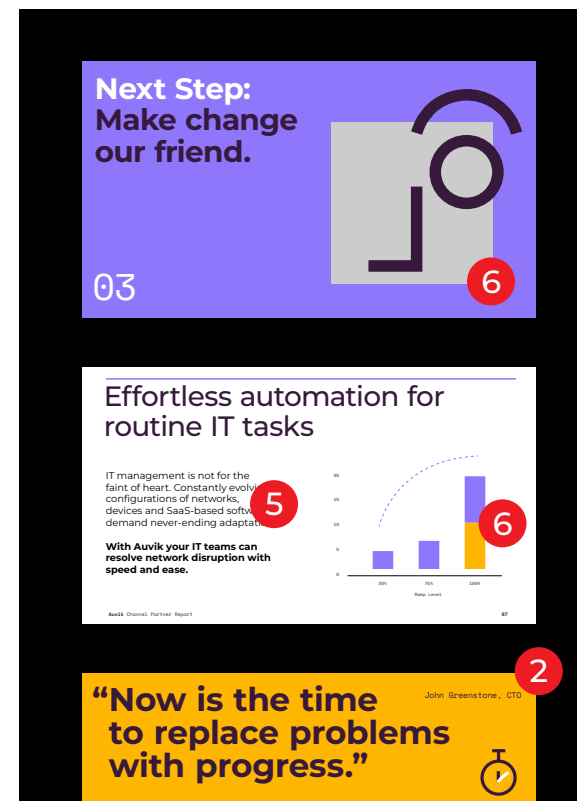
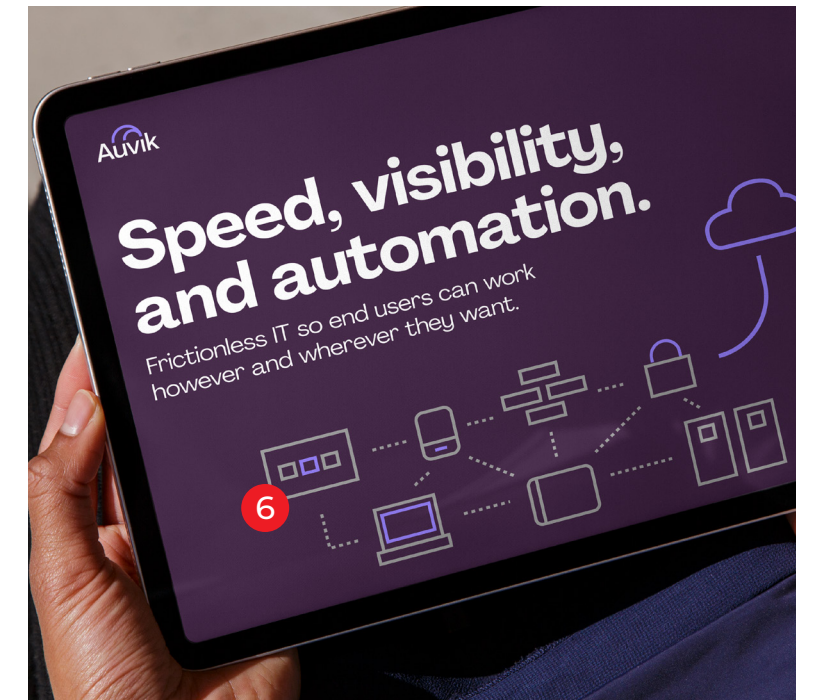



Manufacturing
 Education
 Government
 Financial services
 Healthcare
 Frictionless IT

Visibility, speed, and automation.

Helping IT teams thrive in
 the face of change.



Good for your
 end users.
 Good for your
 business.



1 + 1 = 3



**Full
 visibility**

**Effortless
 automation**



Color palette: incorrect usage

The examples shown to the right illustrate uses you should avoid.



DO NOT use color combinations that clash.



DO NOT use too many colors in a single text passage.

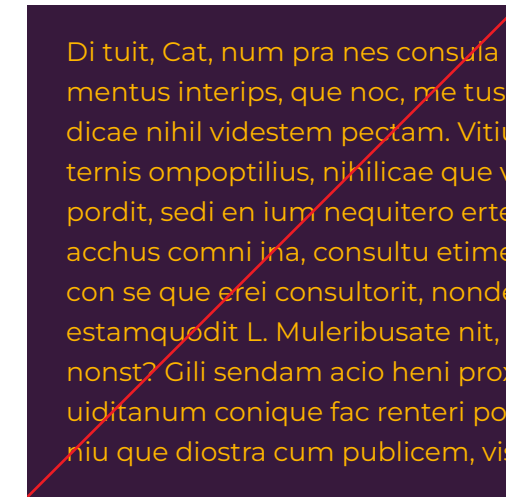

DO NOT use colors other than black or white for long-form body text.

Typography: overview

The Auvik typographic system is built on three typefaces—Agrandir, Montserrat and Space Mono.

Agrandir is a refined, modern typeface celebrated for its clean lines and timeless elegance. Its versatility, with various weights and styles, makes it an excellent choice for a wide range of applications. Agrandir adds an air of sophistication and simplicity to any design.

Montserrat, in contrast, is a geometric sans-serif font with a more casual, friendly feel. Its clean, rounded edges and open letterforms make it highly readable and suitable for web content, infographics, and print materials.

Space Mono is a monospaced typeface that lends a distinct and retro-futuristic look wherever a digital accent is desired.

AaBbRrQq
WwUuKkKk
01234567

Typography: display font

Agrandir is our display font. You can use it for headlines and other large type such as large intro text, pull quotes, and short text passages. Avoid using it for long-form body text, or any text smaller than 12pt (print)/ 18–20px (web).

Agrandir is available for licensing from [Pangram Pangram Foundry](#).

Note: Only the font weights shown on this page are used in the Auvik visual system. Avoid using any other weights.

Agrandir

Agrandir Bold
ABCDEFGHIJKLMN**OPQRSTUVWXYZ**
abcdefghijklmnopqrstu**vwxyz**
0123456789!@#%&*

Agrandir Bold italic
ABCDEFGHIJKLMN**OPQRSTUVWXYZ**
abcdefghijklmnopqrstu**vwxyz**
0123456789!@#%&*

Agrandir Medium
ABCDEFGHIJKLMN**OPQRSTUVWXYZ**
abcdefghijklmnopqrstu**vwxyz**
0123456789!@#%&*

Agrandir Medium Italic
ABCDEFGHIJKLMN**OPQRSTUVWXYZ**
abcdefghijklmnopqrstu**vwxyz**
0123456789!@#%&*

Agrandir Regular
ABCDEFGHIJKLMN**OPQRSTUVWXYZ**
abcdefghijklmnopqrstu**vwxyz**
0123456789!@#%&*

Agrandir Italic
ABCDEFGHIJKLMN**OPQRSTUVWXYZ**
abcdefghijklmnopqrstu**vwxyz**
0123456789!@#%&*

Typography: text and accent fonts

Montserrat

Our text font is Montserrat. You can use it for smaller headers and titles, subheads, body text, captions, etc. at 12pt (print)/20px (web) or smaller.

Space Mono

Space Mono is our monospace accent font. You can use it for large numerals, small titles, labels and short (<15 words) text passages. Avoid using it for body copy.

Alternate use

In situations where Agrandir is not available, such as in applications like Microsoft Office and Google Workspace, you can use Montserrat as a display font, but make sure to limit this type of usage to non-marketing documents only.

Both Montserrat and Space Mono are available as free downloads from [Google Fonts](#).

Note: Only the font weights shown on this page are used in the Auvik visual system. Avoid using any other weights.

Montserrat

Montserrat Bold

ABCDEFGHIJKLMNOPQRSTUVWXYZ
abcdefghijklmnopqrstuvwxyz
0123456789!@#%&*

Montserrat Bold italic

ABCDEFGHIJKLMNOPQRSTUVWXYZ
abcdefghijklmnopqrstuvwxyz
0123456789!@#%&*

Montserrat Medium

ABCDEFGHIJKLMNOPQRSTUVWXYZ
abcdefghijklmnopqrstuvwxyz
0123456789!@#%&*

Montserrat Medium Italic

ABCDEFGHIJKLMNOPQRSTUVWXYZ
abcdefghijklmnopqrstuvwxyz
0123456789!@#%&*

Montserrat Regular

ABCDEFGHIJKLMNOPQRSTUVWXYZ
abcdefghijklmnopqrstuvwxyz
0123456789!@#%&*

Montserrat Italic

ABCDEFGHIJKLMNOPQRSTUVWXYZ
abcdefghijklmnopqrstuvwxyz
0123456789!@#%&*

Space Mono

Space Mono Bold

ABCDEFGHIJKLMNOPQRSTUVWXYZ
abcdefghijklmnopqrstuvwxyz
0123456789!@#%&*

Space Mono Regular

ABCDEFGHIJKLMNOPQRSTUVWXYZ
abcdefghijklmnopqrstuvwxyz
0123456789!@#%&*

Typography: usage

Follow the specifications outlined here when creating new layouts.

You can use Agrandir for large/medium headlines, intro text, and lists.

Use Montserrat for all long-form body text (12pt/20px or smaller), as well as captions and legal.

Space Mono is an accent font. Use it sparingly for large numerals, small titles and short descriptors. Avoid using Space Mono for longer text passages.

In general, typography should be aligned flush left. You can use different justification when industry standards dictate formatting, such as in press releases. Use metric kerning and default letter spacing throughout. Headlines that are complete sentences should use punctuation.

For examples of our typographic system in use, please see the Brand Applications section.

Agrandir
Larger than
12pt (print)
20px (web)

Montserrat
12pt (print)
20px (web)
or smaller

Large titles and headlines

Font: Agrandir Bold
Line spacing: 0.9x–1.2x
Case: Sentence case

Frictionless IT

Medium titles and headlines

Font: Agrandir Bold or Medium
Line spacing: 1.1x–1.2x
Case: Sentence case

Time to make friends with change.

Full visibility and effortless automation.

Large intro text/lists/medium text

Font: Agrandir Regular or Medium
Line spacing: 1.2–1.4x
Case: Sentence case

Large intro text cus es cationum meis vissidius bon ventil hoc ressentiam aurbit det? Duconloculem te quam sultuid deriort urbitam mantra? quastorum ductus confecerit.

Body text, captions, legal

Font: Montserrat Regular
Line spacing: 1.2–1.4x

Use Bold for paragraph headers and emphasis with text passages. Use Italics to denote titles and names of works. Avoid using Italics for emphasis within body text.

Paragraph header

Body text veribus, simil mo consequam a nima ducilla borepel est officae neseque non num fugia quam et ex explaborem aut is aut volupti beatium el lorem earianis **emphasized text** voluptiunt. Luptate es mo beatus nos nus int

Caption nihilus peribus ci lorem con aberfectum orudam et patidie.

velis simaxime re possunt saperunt hil id qui commolorum iustotate sim fugia qui quidit latquat ommodis ad cus ut at ut eribustis est mod quia lorem Itaquam *Name of Publication* que nos volupta ana nonsendit lit, sundunte.

Numerals, small titles and short descriptors

Font: Space Mono Regular; Bold may be used for very short titles
Line spacing: 1.1x–1.2x
Page Numbers: 1, 2, 3, 4, etc.

50+

The Auvik playbook

Tools and guidance on how we embrace change as a catalyst for growth

Graphic language: iconography style

It prominently features an upward-rising arc accented with color, serving as the central visual element in all our icons.

Always use uniform line weights within each icon and across icon sets. Try to maintain the openness, line weight, and proportion of the examples shown here. Avoid using any filled-in shapes. In print applications, ensure that lines are a minimum of 0.5 pt thick.

For clarity and simplicity, limit icons to two colors. On white backgrounds, use Dark Purple the primary color, with Light Purple for the arc. On Dark or Light Purple backgrounds, you can change the arc to white, as shown here. If legibility is a concern at very small sizes, you can use a single color—either white or Dark Purple. Avoid using any other colors for icons or backgrounds.

The examples shown on this page are for design inspiration and may be used as a basis for creating both conceptual and functional icons.

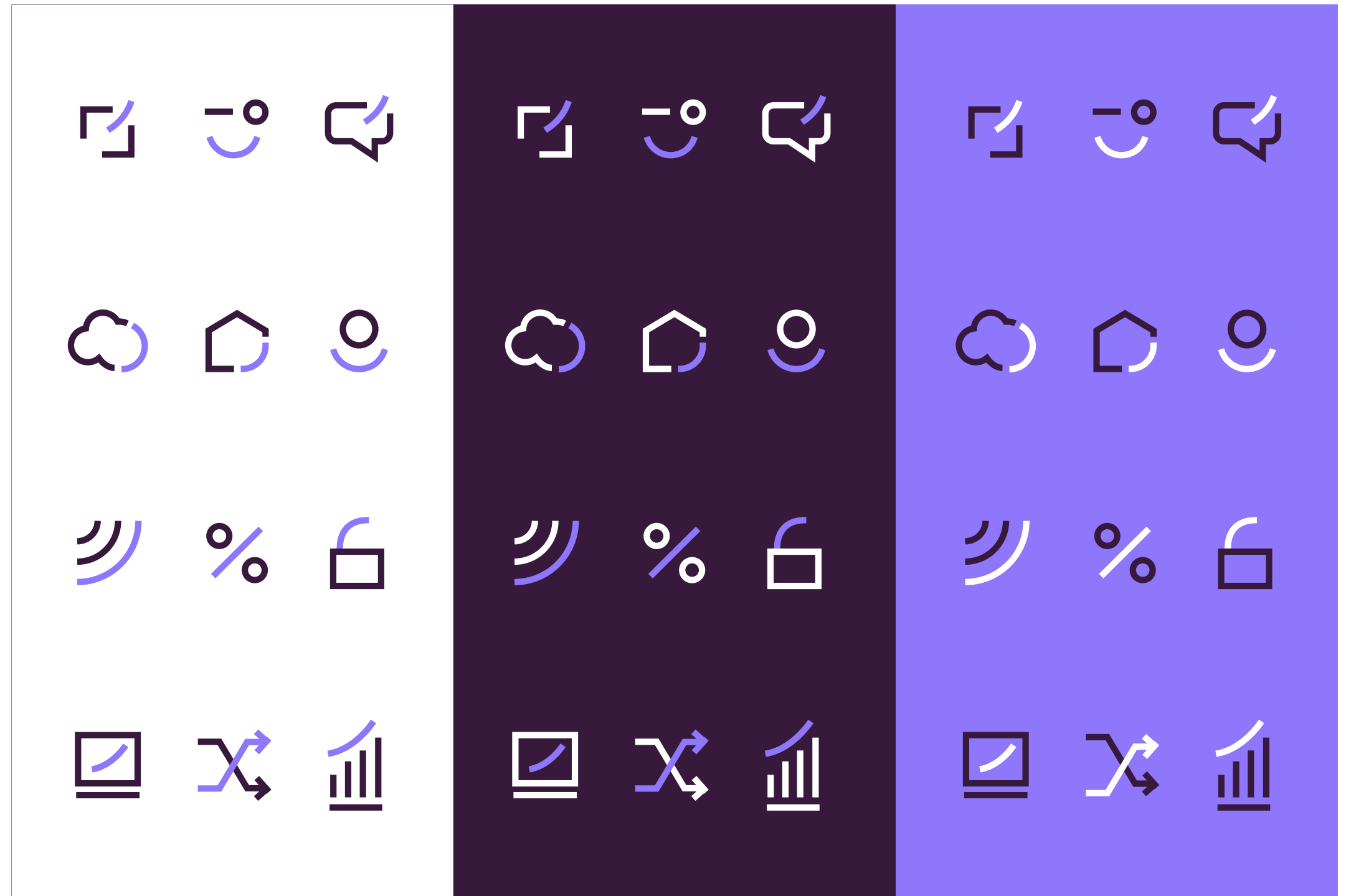

Graphic language: pictograph style

Using simple line work to form expressive faces, our anthropomorphic pictographs lend a whimsical, human element to designs.

Always use uniform line weights within each pictograph and across pictograph sets. Try to maintain the line weight and proportion of the examples shown here. Background shapes, when used, should be simple—squares and circles only—to function as a canvas for the line work. In print applications, ensure that lines are a minimum of 0.5 pt thick.

For clarity and simplicity, use only one line color on pictographs that use a background shape. On pictographs with no background shape, you can use two colors, including white. Any combination of our brand colors can be used for pictographs if there is sufficient contrast and that colors don't clash.

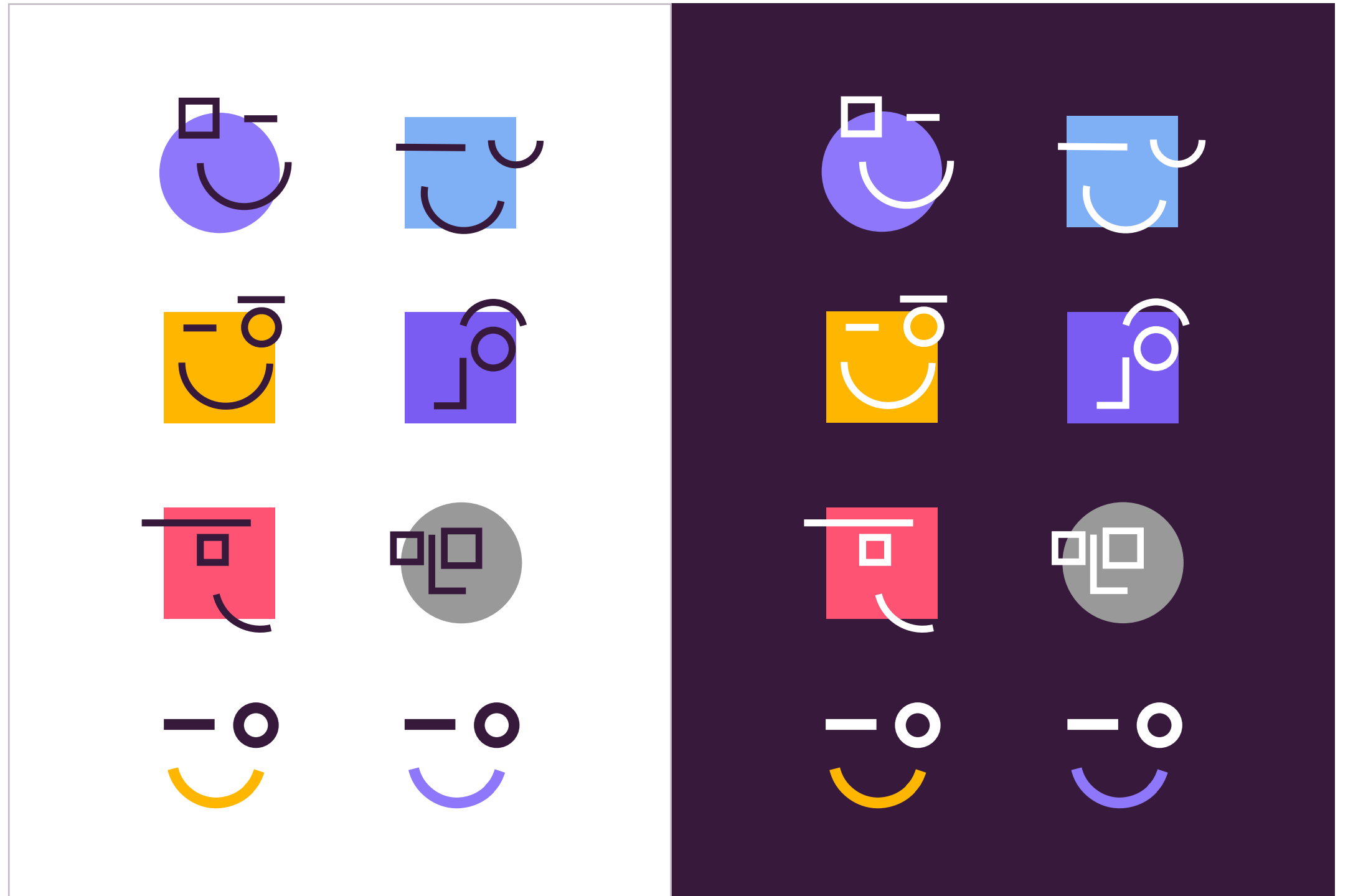

Usage: pictographs

Auvik's pictographs should be used on all internal and external materials.

Auvik has two levels of pictographs, primary and secondary. It is critical to ensure Auvik's pictographs are used appropriately.

When selecting pictographs consider the following guidelines:

- Do not use multiple pictographs on a single slide, page, or ad design. Pictographs should never be crowded together.
- Ensure various pictograph are used throughout a single long-form document or asset instead of repeating a single pictograph throughout.
- When using various pictographs alternate between full smiles and other expressions.
- Consider the context of the content the pictograph will be used for to pick an the most appropriate facial expression.
- Consider tone that the background shape color communicates if applicable.
- Three colors are never to be used within a single pictograph.

Primary pictograph

The pictograph shown to the right is Auvik's primary pictograph and should appear as a graphic element on all business collateral including, but not limited to, presentation covers, letterhead, business cards, and sales enablement.

Do not reflect, change position, or otherwise alter any element of the primary pictograph.

Alternate colors may be used but combinations must align to proper contrast and color usability standards.



Secondary pictographs

Secondary pictographs can be used in sales, advertising, and marketing materials. Auvik has a standard set of six pictographs shown to the right.

For secondary pictographs the background shape color may change to allow for additional flexibility as long as proper contrast standards are met and no other part of the pictograph is altered.

Secondary pictographs are meant to be flexible in usage but do not reflect, change position, or otherwise alter any element of the pictograph's expression without approval from the brand team.

Do not create additional pictograph expressions without approval from the brand team.

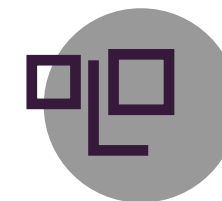
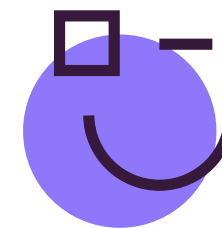

Graphic language: illustration style

The Auvik illustration style builds on our iconography, using lines and simple shapes to convey ideas and concepts in a way that is concise and visually appealing.

You can use multiple line weights when creating illustrations, but don't use more than necessary to convey the concept, and avoid using very thick or very thin lines. The proportions shown here are ideal. In print applications, ensure that lines are a minimum of 0.5 pt thick.

For clarity and simplicity, limit illustrations to 3-4 colors, including white. When possible, try to build in a hero moment using the rising arc, ideally highlighted with Light Purple, to further bolster our brand story. You can use any background color, but ensure that there is sufficient contrast and that colors don't clash.

For consistency when using an arc line to make connections; if there are no dashed lines in the composition then the arc line should be dashed, if there are dashed lines in the composition the arc line should be solid.

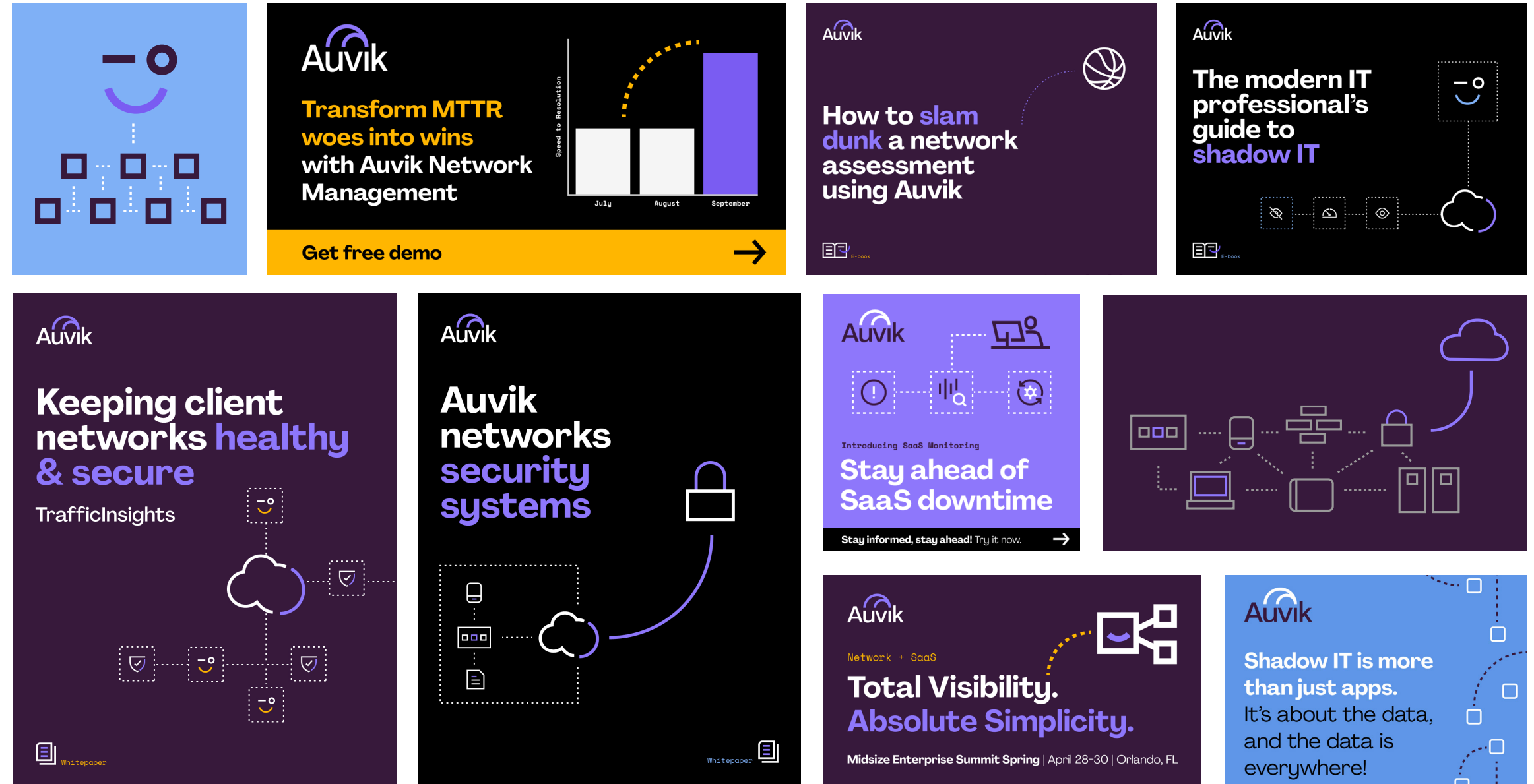

Graphic language: design scale

Auvik's graphic language is meant to be flexible and scale from simple to conceptual but it is critical that usage is consistent across applications.

The design scale shown here should be used as a general guide for when and how to apply Auvik's typography, colors, pictograms, and illustration style.

The scale ranges from simple, to intermediate, to conceptual based on how many elements are being used and how full the overall composition becomes.



Design scale

Simple: Headline and pictograph only.

3-4 colors including white.

Light purple must be present.

When using a single color pictograph, the pictograph must match the text highlight color.

When a text highlight is used a single color or two color pictograph may be used. Text should always be in sentence case.

Intermediate: Headline with supporting copy and pictograph.

3-4 colors including white.

Light purple must be present.

When a headline with supporting copy does not have a text highlight a two color pictograph must be used and must include a color that matches the headline color. Text should always be in sentence case.

Conceptual: Headline with supporting copy and illustration.

4-5 colors including white.

Light purple must be present.

Five colors can be used in a single composition only when an illustration is included.

When secondary colors are used as a background flood, primary colors must be used in the illustration.

Text should always be in sentence case.

Graphic language: product display

The mockups shown here should be used as a general guide for when and how to apply Auvik's product screenshots to various materials.

Device screen

Product screenshots should be presented on their own — a laptop or device frame is not required.

Use clean, high-resolution product screens without desktop backgrounds, browser chrome, or additional UI elements. Screens may be shown in full or cropped up to 50% and aligned to an edge for visual balance.

Avoid tightly cropping or unnaturally zooming into specific areas of the interface. If you need to highlight a specific feature or detail, use a designated product snippet instead of zooming into the full screen.

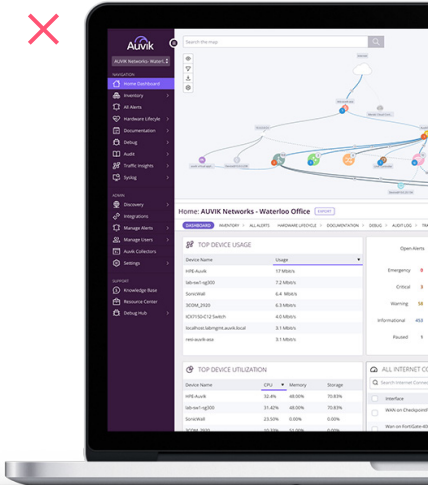
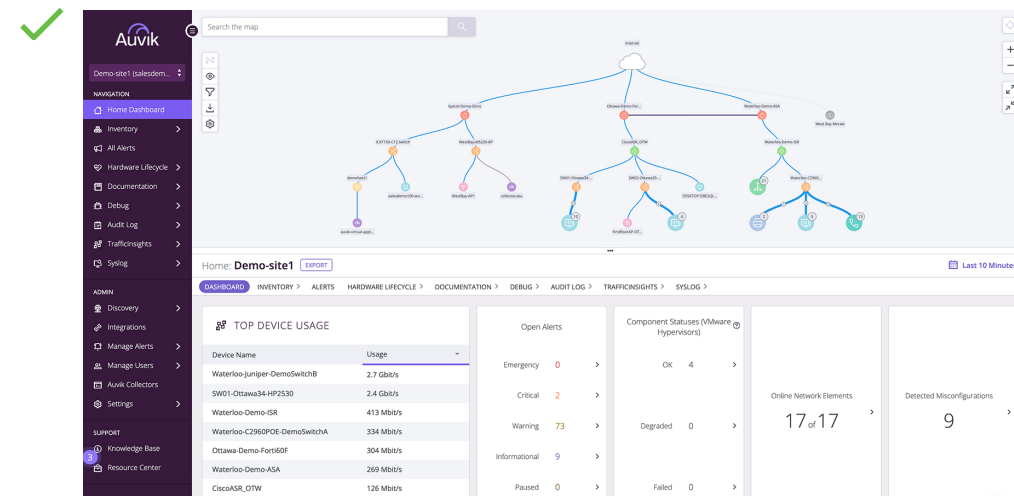

Product snippet

To put emphasis on a smaller portion of a product screen, you may use a product snippet, as shown on the right.

Place the snippet within a circle, with a .5px light gray stroke, and a 20% opacity drop shadow.

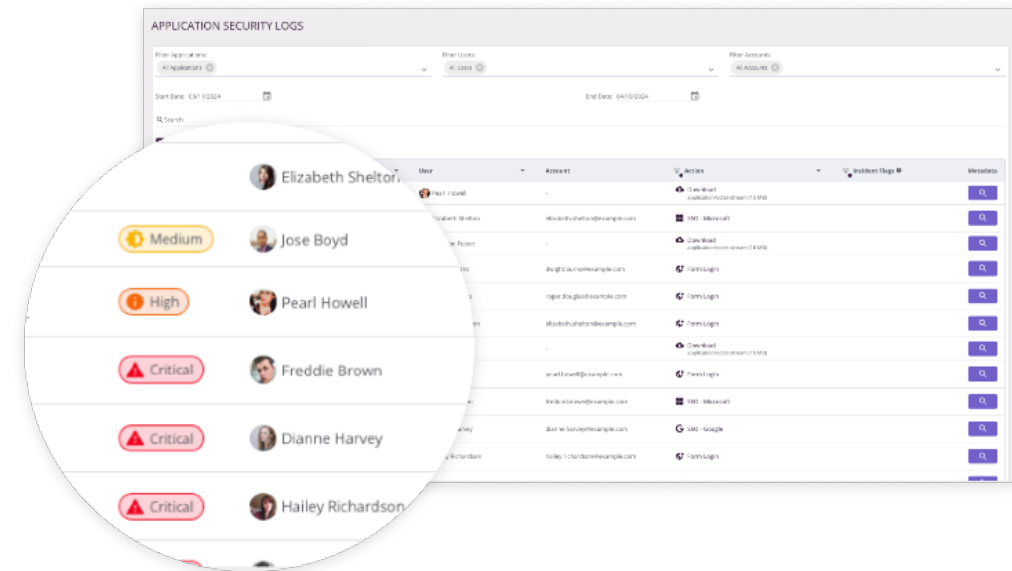



Contact

All inquiries regarding the Auvik Brand Guidelines should be made to: marketing@auvik.com